



Kjellberg®
FINSTERWALDE

Kjellberg Finsterwalde
Schweißtechnik und Verschleißschutzsysteme GmbH
Automation Solutions



Basis for your success

85 years of experience – the basis of our expertise
Tradition – our commitment to innovation

With more than 85 years of experience in the welding industry, KSV has a high level of expertise in delivering customised automation solutions.

Beginning with the mechanisation of stick welding processes in 1934, Kjellberg Finsterwalde played a major part in the development of **submerged arc welding (SAW)**. Since that time Kjellberg welding systems have formed the basis for successful solutions in the metal industry and in trade.

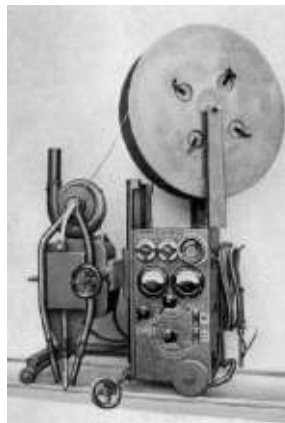

Kjellberg automat (1938)



Kjellberg KA automat (2008)

For more than 70 years, KSV welding machines have laid the optimum foundation for a wide variety of rationalisation solutions in metal-working worldwide.

As the basis for customised machines, the innovative Kjellberg KA series follows the tradition of a modern and flexible **modular concept** for customised industrial solutions. The breadth of technical and technological application and the modular system guarantee the user **maximum performance and top quality** automation technology geared to customer specifications.



Customised Kjellberg system solutions

The outstanding features of KSV automation solutions include their optimised mechanical assemblies and the use of modern electronics for simple control and presetting. Automatic and preset parameters for start/stop, crater filler and burn-back as well as speedometer-controlled drives for tractor and wire feeder are par for the course, as are the robustness and user-friendliness of the control unit and the mechanical system.





The range is enhanced by other available modifications, such as flux recovery unit, documentation of welding parameters, sensor systems and wire to seam controller.

The modern Kjellberg concept reduces demands on operating personnel and ensures consistently high standards of production quality for the following:

- **Variations: SAW and GMAW**
- **Range of operations: butt welds, fillet welds, cladding**
- **Single, double or multiple wire technology (parallel or tandem)**
- **Welding with one or two welding heads**

Combined with approved Kjellberg DC power sources (400 to 1,200 A with a duty cycle of 100% CV / CC characteristic), the result is a wealth of options in terms of made-to-measure solutions with maximum economic benefit for a faster return on capital employed.

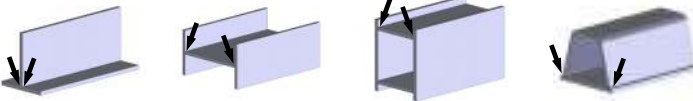
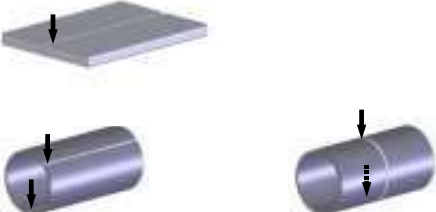
Our catalogue contains **various ideas as to how you might mechanise or automate your welding jobs**, with examples of Kjellberg applications for frequently recurring production processes customised as system solutions for the following:

Fillet welds	from page 4	
Butt welds	from page 14	
Longitudinal and round seam welds (inside and outside)	from page 24	
Surfacing (cladding, buttering, hard-surfacing, regeneration)	from page 30	

Profile and beam welding system

Automatic SAW welding gantry – type KU



Application

Box beam welding with max. 300 mm component preload

SAW welding

Fillet welds

Thicknesses from 10 to 20 mm

Maximum component dimensions 60,000 x 1,500 x 2,500 mm

Materials: S235, S355

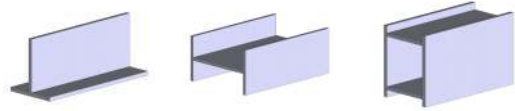

Features	<p>Production of box beams up to 2,500 mm in height</p> <p>On-board operation platform with all control elements for each working section and camera system</p>
Target	<p>50% reduction in secondary time gained through single turn-over of workpiece. The gantry enables the welding of all seams in horizontal position</p> <p>Set-up times minimised by automatic balancing of location deviations up to 750 mm</p> <p>High flexibility as regards profile component due to custom portal construction, leading to high potential savings through versatility of application</p>
System components	<p>2 DC welding power sources – type GTH 1002</p> <p>2 motorised flux recovery units</p> <p>Inductive seam tracking system</p>
Performance range	<p>100A/19V up to 1,000A /44V at 100% duty cycle</p> <p>Welding speeds of up to 80 cm/min</p> <p>Diameter of welding wire of up to 5 mm</p> <p>Fillet welds in PB position (horizontal vertical)</p>
Applied benefits	<p>High productivity due to fully automatic beam welding – approx. 70% reduction in working time</p> <p>Simultaneous welding of both fillet welds including automatic balancing of the direction deviations</p> <p>Set-up time minimised by closed flux recovery</p> <p>Entire welding process overseen and controlled from an operating platform</p>

Beam welding system

Fully automated SAW welding gantry – type VWS



Application

Joint welding of steel plates into carrier sections with boundary fillet welds

SAW welding

Fillet welds

Thicknesses from 8 – 16 mm

Maximum dimensions: 22,000 x 1,400 mm (base height)

Materials: S235, S355, shipbuilding steel

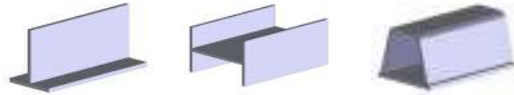

Features	<p>SAW gantry for welding of components in longitudinal direction</p> <p>Internal heavy-duty tractor for complete welding assembly support</p>
Target	<p>Productivity boosted to approx. 130% through automatic carrier section welding</p> <p>Enhanced process reliability through elimination of human error in manual welding</p> <p>High production efficiency and considerable reduction in workload through appropriate workpiece handling</p> <p>High-grade and robust process technology for optimum welding results combined with longevity of systems engineering</p>
System components	<p>2 power sources – type GTH 802</p> <p>2 SAW single wire welding heads</p> <p>Mechanical seam tracking system using hinged arm technology</p> <p>Motorised flux recovery system</p> <p>Main control console for welding and on-board peripherals in the welding area</p>
Performance range	<p>80A/18V up to 720A/44V at 100% duty cycle</p> <p>Welding speeds of up to 70 cm / min</p> <p>Diameter of welding wire max. 2.5 mm</p> <p>Fillet welds in PB position (horizontal vertical)</p>
Applied benefits	<p>Component warpage minimised by simultaneous fillet welding</p> <p>Secondary processing time reduced thanks to two side by side workpiece supports</p> <p>Hinged arm technology for perfect seam tracking even with nonlinear welding seams</p>

Beam welding system

Fully mechanised GMAW welding gantry – type HUE



Application

Joint welding of plates to longitudinal beams with required angle deviations of up to 13°

GMAW welding

Fillet welds

Material thicknesses of 8 to 16 mm

Maximum workpiece dimensions 9,500 x 500 x 200 mm

Materials: S235, S355

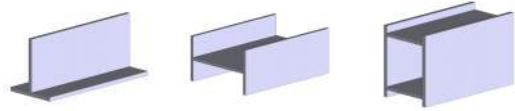

Features	Automation of beam welding for increased productivity compared to semi-mechanised welding process used hitherto
Target	<p>Productivity boosted by around 70% through automatic welding of the beams including torch control in angular range</p> <p>Time saved on stitch process by using separate fixture elements</p> <p>Reduced set-up time through simultaneous feeding of two parallel workpiece tables</p>
System components	<p>2 GTH 522W power sources with separate wire feeder</p> <p>2 water-cooled GMAW machine torches with double cooling system and angularity of 45°</p> <p>Tactile seam tracking straight in front of the welding arc</p>
Performance range	<p>70A/18V to 400A/34V at 100% duty cycle</p> <p>Welding speeds of 70 cm/min</p> <p>Diameter of welding wire 1.2 mm</p> <p>Fillet welds in PB position (horizontal vertical)</p>
Applied benefits	<p>Time saved by automated beam welding with cut-off system component-oriented welding limit stop</p> <p>Simultaneous welding of both fillet welds, including tracking of existing angle deviations</p> <p>Considerable reduction in secondary process time through automation, elimination of stitch process and positioning of both beams in a narrow gap</p> <p>Workpiece warpage minimised by simultaneous welding of both fillet welds</p>

Beam welding system

Fully mechanised heavy-duty GMAW welding tractor

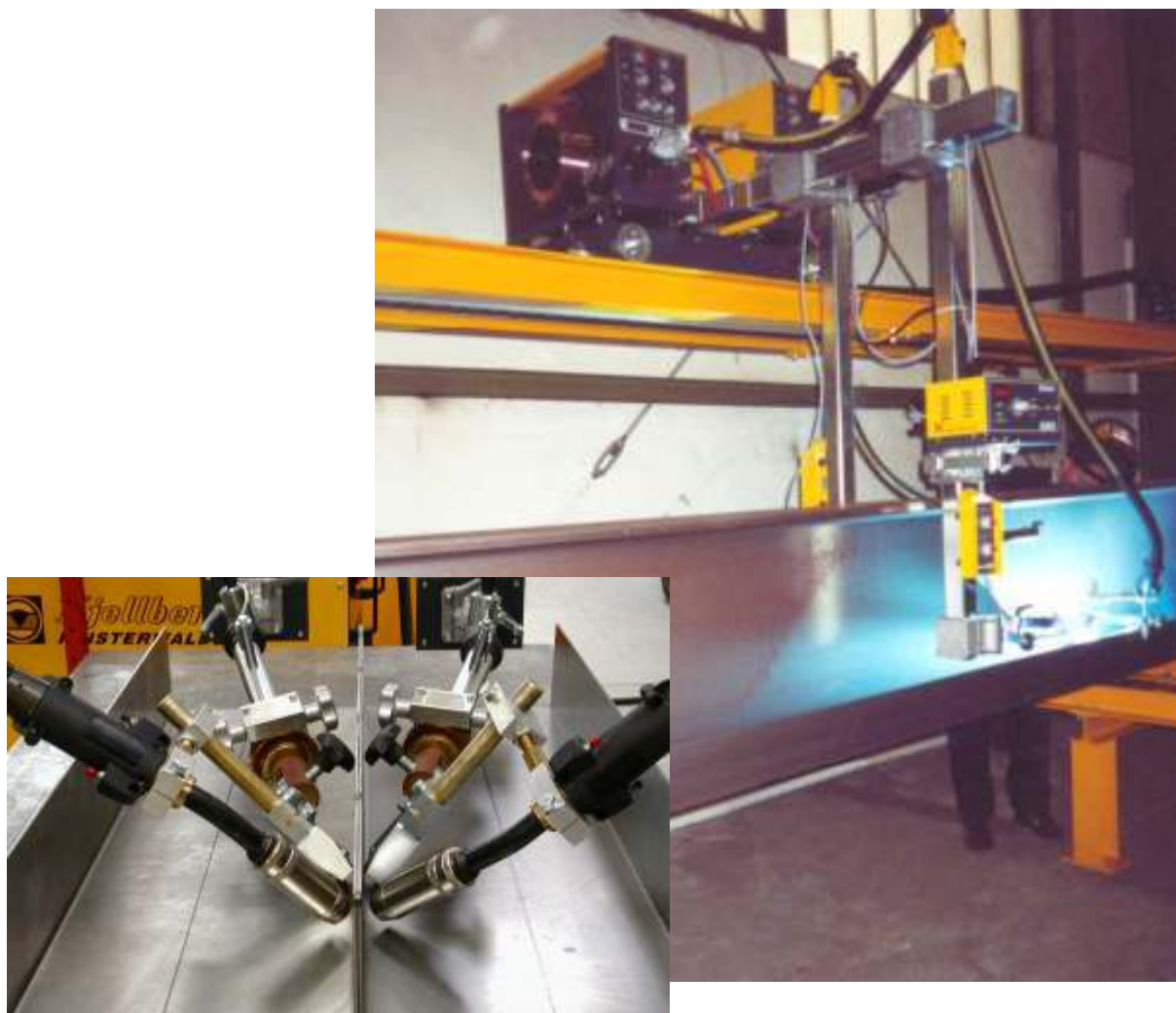

Application

Construction welding of plates to carrier sections

GMAW welding

Fillet welds

Thicknesses from 8 – 25 mm

Maximum dimensions 25,000 x 500 x 1,200 mm

Materials: S235, S355

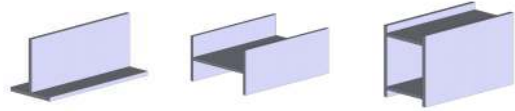

Features	Mechanised longitudinal carrier section welding deploying heavy-duty tractor on roadway
Target	<p>Significant cost reduction through the use of heavy-duty machine technology compared to the originally planned construction portal</p> <p>High flexibility through applicability for different carrier sections due to the long boom and by using hinged arm technology</p> <p>Secondary process time minimised by bilateral workpiece feeding along roadway – positioning on a swivel joint on the rail carriers</p>
System components	<p>2 power sources – type GTH 522W</p> <p>2 water-cooled GMAW machine torches capable of withstanding 500A</p> <p>2 DV 4W-1 wire feeders</p> <p>Four-wheel heavy-duty tractor, track width 540 mm, with swivel joint for welding equipment</p> <p>Mechanical seam tracking through guided rolls on GMAW hinged brackets</p> <p>Plant-floor control panel with all display and functional elements</p>
Performance range	<p>70A/18V to 400A/34V at 100% duty cycle</p> <p>Welding speeds of up to 100 cm/min</p> <p>Diameter of welding wire max. 1.6 mm</p> <p>Fillet welds in PB position (horizontal vertical)</p>
Applied benefits	<p>Productivity increased by about 40% and process reliability enhanced by mechanised welding process</p> <p>Workpiece warpage minimised by simultaneous welding of both fillet welds</p> <p>Approx. 30% reduction in secondary process time thanks to second workpiece table at opposite side of roadway</p>

Beam welding system

Fully mechanised double hinged joint arm automat – type KA 4-UPDG



Application

Joint welding of sheet metal, plates and rolled sections to box sections

SAW welding

Fillet welds and butt welds

Thicknesses of up to 30 mm

Max. dimensions 30,000 x 1,500 x 800 mm

Material: S355



Features	<p>Modified welding machine for simultaneous welding of opposite fillet welds</p> <p>Seam tracking through guided rolls and hinged arm</p> <p>Welding of components preheated to 200°C</p>
Target	<p>Installation costs reduced to approx. 35% by using machine technology as opposed to portal construction</p> <p>Major reduction in set-up time through flexibility and easy tractor handling</p> <p>Cost reduction through added versatility of optional equipment with plasma cutting torches for gouging the sealing run</p> <p>Integrated hinged arm technology for versatility of application with regard to workpiece geometry and seam type and position</p> <p>Option of fitting oxyfuel torches on hinged brackets for preheating</p>
System components	<p>Modified double joint arm automat</p> <p>2 power sources – type GTH 802</p> <p>2 pneumatic flux recovery units</p>
Performance range	<p>80A/18V to 720A/44V at 100% duty cycle</p> <p>Welding speeds up to 60 cm/min</p> <p>Diameter of welding wire up to 2.5 mm</p> <p>Fillet welds and butt welds in PA position (flat) and PB position (horizontal vertical)</p>
Applied benefits	<p>Significant increase in productivity and reduction in workload through high degree of mechanisation</p> <p>Significant improvement in quality – error rate for ultrasound and X-ray examinations down to 0.5%</p> <p>Maximum processing route dependent only on media supply</p>

Beam welding system

Fully mechanised SAW tandem welding gantry – type TE



Application

Joint welding of plates to various types of heavy-duty beams

SAW tandem welding

Fillet welds and butt welds

Plate thicknesses from 50 to 180 mm

Max. workpiece dimensions 15,000 x 1,600 x 1,400 mm

Material: S355

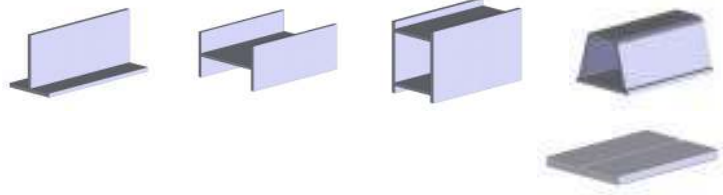

Features	Existing portal with double-wire equipment has been converted to Kjellberg tandem technology
Target	<p>Considerable boost in productivity to 150% through automation of beam manufacturing</p> <p>Major increase in welding productivity thanks to the use of tandem technology</p> <p>Quality guaranteed by high level of automation plus powerful and reliable welding processes</p>
System components	<p>1 DC power source – type GTH 1002</p> <p>1 AC power source – type TTH 1000</p> <p>1 SAW tandem welding head, tilt adjustable left/right</p> <p>Motorised flux recovery unit with pressure conveyor</p>
Performance range	<p>100A/19V to 1,000A/44V at 100% duty cycle – DC</p> <p>200 A to 1,000A at 100% duty cycle – AC</p> <p>Welding speeds of up to 80 cm/min</p> <p>Diameter of welding wire 3 – 4 mm</p> <p>Single-bevel butt weld</p>
Applied benefits	<p>50% increase in performance through very high welding speed and excellent welding performance</p> <p>High-quality workmanship thanks to effective weld seam geometry with improved mechanical characteristics</p> <p>Workpiece warpage minimised by reduced energy input</p>

Beam welding system

Fully mechanised SAW welding gantry – type DE



Application

SAW longitudinal welding of box girders, T beams and trapezoid cross sections

SAW parallel welding

Fillet welds, optional butt welds

Thicknesses of 8 – 30 mm

Max. workpiece dimensions 35,000 x 6,000 mm under preload, (separate clamping device), 35,000 x 10,000 mm without preload, box girder max. 35,000 x 1,500 x 1,000 mm

Materials: S235, S355

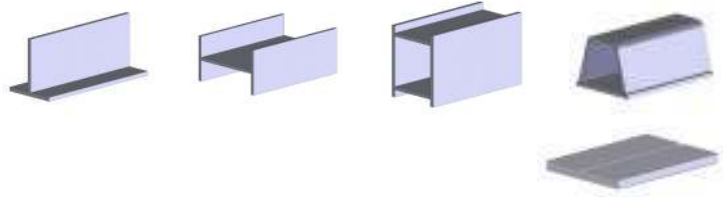

Features	<p>Mechanisation of longitudinal welding</p> <p>Facility for welding in all four directions thanks to rotating column</p>
Target	<p>Significant time saving by utilising entire portal width and full length of workpiece table</p> <p>Preset parameters guaranteeing seam quality, process reliability and easing the workload of operating staff</p>
System components	<p>2 DC power sources – type GTH 1002</p> <p>2 modified parallel wire welding heads with continuous adjustable wire positioning</p> <p>Inductive seam tracking system</p>
Performance range	<p>200A/28V to 1,000A/44V at 100% duty cycle</p> <p>Welding speed up to 100 cm/min</p> <p>Wire diameter for each welding head 2 x 3 mm</p> <p>Fillet welds in PB position (horizontal vertical), butt welds in PA position (flat)</p>
Applied benefits	<p>Significant reduction in secondary time through eliminating portal runtime – using a 270° rotating column</p> <p>Workpiece warpage minimised by simultaneous welding of both fillet welds</p> <p>Set-up time reduced by automatic tracking with existing angle and plate thickness deviation</p>

Beam welding system

Fully mechanised SAW gantry – type WI



Application

Joint welding of plates to profiles and panels

SAW parallel welding

Main specialisation in fillet welds, optional butt welds

Thicknesses of 8 – 30 mm

Max. workpiece dimensions 8,500 x 1,500 mm

Materials: S235, S355

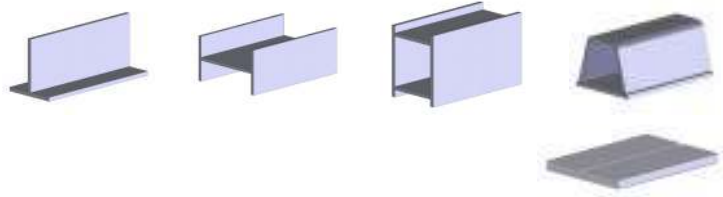

Features	Fully mechanised gantry with double wire technology for increased productivity in comparison to a semi-mechanised welding process with single wire technology
Target	<p>High productivity thanks to time saved by automated welding of profiles, beams and panels</p> <p>Extreme flexibility regarding workpiece dimensions due to large span and potential action radius of portal</p> <p>Staff workload reduced by preset process parameters and ease of operation while maintaining excellent product quality</p>
System components	<p>2 DC power sources – type GTH 1002</p> <p>2 modified parallel wire welding heads with continuous adjustable wire positioning, capable of withstanding 600 A</p> <p>Mechanical seam tracking system aided by role guides on hinged arms</p> <p>Motorised flux recovery unit, exhaust air filtering and visual level indicator</p>
Performance range	<p>200A/28V to 1,000A/44V at 100% duty cycle</p> <p>Welding speed 20 – 200 cm/min</p> <p>Wire diameter per welding head 2 x 2.5 mm</p> <p>Fillet welds from a = 6 mm in PB position (horizontal vertical), butt welds in PA position (flat)</p>
Applied benefits	<p>High production time savings, minimisation of workpiece warpage and reduction in amount of post-processing required by simultaneous welding of both fillet welds</p> <p>Set-up time reduced by automatic tracking with existing angle and plate thickness deviation</p> <p>Significant reduction of secondary process time thanks to ample working width and large workpiece support for multiple charging</p>

Profile welding system

Fully mechanised GMAW welding gantry – type AK



Application

Joint welding of plates for assembly of ship sections

GMAW welding

Fillet welds and butt welds

Thicknesses from 8 – 20 mm

Max. range of operation 70,000 x 10,000 x 500 mm

Materials: S235, S355, shipyard steel

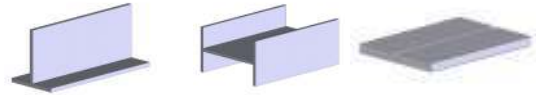

Features	<p>Mechanisation of section production for increased productivity compared to the typical semi-mechanised welding process</p> <p>Gantry dimensions: 11,800 x 4,200 x 3,200 mm</p> <p>270° swivel pillar for welding in four directions</p>
Target	<p>Production time shortened to 50% by vast work area and removal of portal return</p> <p>High weld quality and process reliability thanks to selectable program sequences</p> <p>Staff workload eased by simple operation while increasing product quality</p>
System components	<p>2 DC power sources – type GTH 802 – with external cooling units</p> <p>2 water-cooled GMAW push-pull machine torches</p> <p>Inductive seam tracking system</p>
Performance range	<p>80A/18V to 720A/44V at 100% duty cycle</p> <p>Welding speeds of up to 100 cm/min</p> <p>Flux cored wire with a diameter of 1.4 mm</p> <p>Solid wire with a diameter of 1.2 mm</p> <p>Butt welds in PA position (flat)</p> <p>Fillet welds in PB position (horizontal vertical)</p>
Applied benefits	<p>High savings in production time and minimal component warpage thanks to simultaneous welding of both fillet welds</p> <p>Secondary process time reduced by simultaneous charging of work area with several workpieces</p> <p>Four possible welding directions thanks to rotating holder pillar</p>

Butt welding system

Fully mechanised SAW welding automat with a linear compensation axis

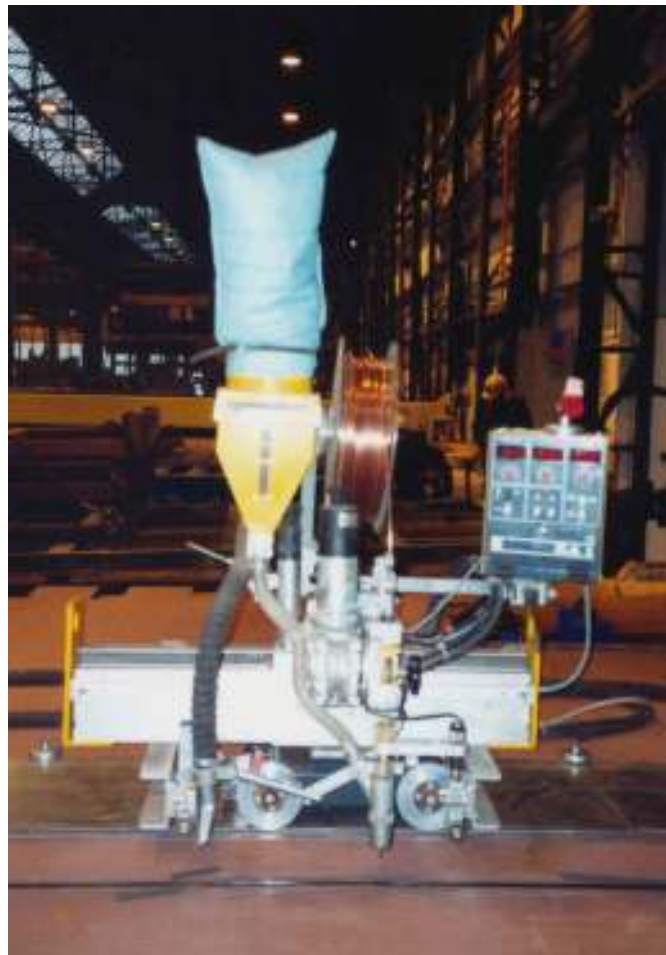

Application

Joint welding of plates to large panels

SAW welding

Butt welds

Thicknesses from 8 – 20 mm

Materials: S235, S355



Features	Modified standard SAW automat featuring a drive shift system for the machine drive in linear axis
Target	Significant saving in production time (approx. 40%) by welding full plates without interruption until the end of process Minimum investment costs through use of machines modified to customer specifications Huge increase in seam quality through elimination of discontinuities at the end of seams
System components	1 DC power source – type GTH 1002 SAW welding head for single wire Linear axis with mechanised switching
Performance range	100A/19V to 1,000A/44V at 100% duty cycle Welding speeds of up to 60 cm/min Diameter of welding wire 3 – 5 mm Butt welds in PA position (flat)
Applied benefits	No post-processing required on seam ends thanks to use of fully mechanised welding system with run-out plates Increased productivity and process reliability due to customised machine modification Reduction in working time due to minimised set-up time through elimination of start and stop plates

Tank welding automat

Fully mechanised SAW welding automat – type SOL

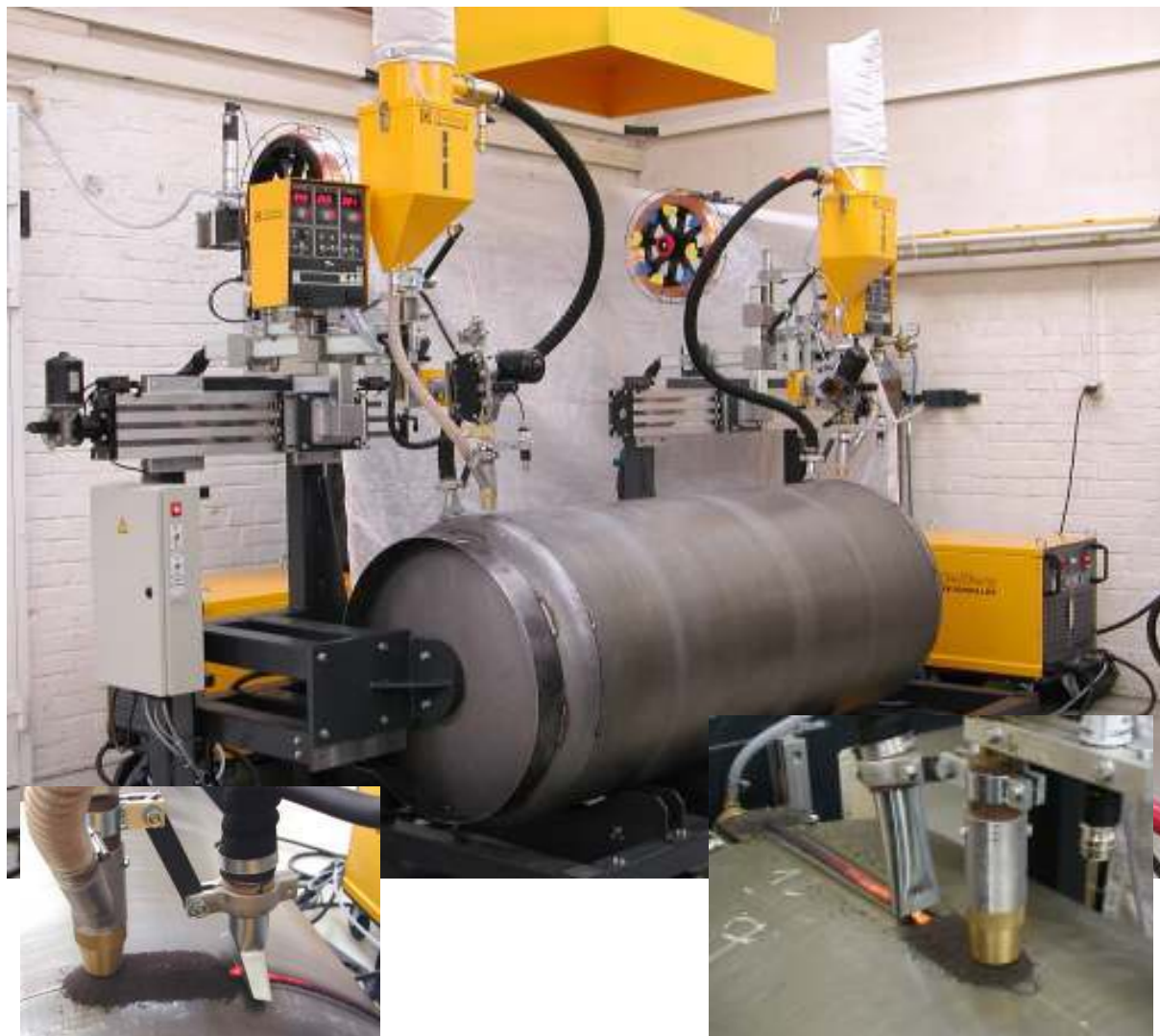

Application

Joint welding of rolled steel sheets

SAW welding

Circular and longitudinal seams (2 separate installations)

Thickness 3 mm

Tank diameter max. 800 mm

Tank length 1,800 – 2,300 mm

Material: Structural steel and pressure vessel steel



Features	<p>Solid machinery base with two support combinations and tank rotary device for simultaneous circular welding</p> <p>Solid machinery base with fixing bolt, roller slideway and support combination for longitudinal welding</p>
Target	<p>Very high increase in productivity by more than 150% due to fully mechanised tank production</p> <p>Significant increase in quality through the elimination of human error in manual welding processes</p> <p>Flexible range of application thanks to suitability for production of tanks with various dimensions</p>
System components	<p>3 DC welding power sources – type GTH 522 G</p> <p>3 SAW single wire welding heads, each with optical seam tracking system</p> <p>3 operating consoles for welding process control</p> <p>3 pneumatic flux recovery units</p>
Performance range	<p>70A/18V to 400A/34V at 100% duty cycle</p> <p>Welding speeds of up to 75 cm/min</p> <p>Diameter of welding wire up to 2 mm</p> <p>Circular and longitudinal seams in PA position (flat)</p>
Applied benefits	<p>High production time saving and low-warpage welding due to high welding speeds with very good seam quality</p> <p>High process reliability thanks to centralised control of both circular welding systems</p> <p>Simultaneous welding of tank top and end to minimise workpiece deformation</p> <p>2 separate units for all welding tasks for complete tank production</p>

Tank welding automat

Automatic SAW column and boom manipulator – type DV



Application

Joint welding of rolled stainless steel plates

SAW welding

Circular and longitudinal seams

Thicknesses of 10 – 25 mm

Max. pipe diameter 3,500 m

Material: unalloyed, low-alloyed and
high-alloyed steels



Features	<p>A rotating column and boom manipulator with longitudinal and height axis (X and Z) was equipped with Kjellberg SAW technology</p> <p>The positioning occurs by the roller bock turning device</p>
Motivation	<p>4 degrees of freedom for the production of different tank sizes</p>
System components	<p>1 DC power source – type GTH 802</p> <p>SAW single wire welding heads, separate for mild steel and stainless steel</p> <p>Manual positioning for X and Z axis</p> <p>Central operating console with joystick control of the axes</p> <p>Pneumatic flux recovery with pressure conveyor</p>
Performance range	<p>80A/19V to 800A/44V at 80% duty cycle</p> <p>Welding speed of up to 80 cm/min</p> <p>Diameter of welding wire up to 3.0 mm for stainless steel Diameter of welding wire up to 5.0 mm for mild steel</p> <p>Circular, longitudinal and fillet welds in PA position (flat) and PB position (horizontal vertical)</p>
Applied benefits	<p>Less welding deformation thanks to fast welding speeds and accurate weld quality</p> <p>Process reliability through high-class technology and direct process monitoring by the user</p> <p>Multiple applications by high number of degrees of freedom</p>

Pipe welding machine

Fully mechanised steerable automat – type KA1-UPP

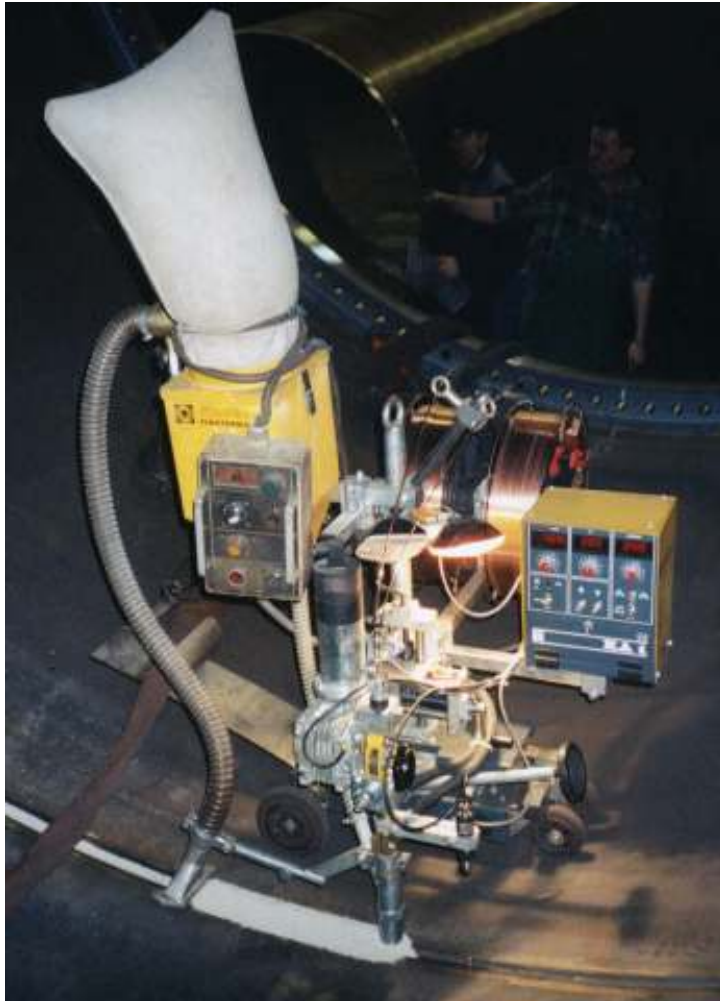

Application

Joint welding of rolled plates to pipe sections

SAW parallel wire welding

Butt welds and fillet welds

Thicknesses of up to 40 mm

Minimum pipe diameter approx. 1,400 mm

Materials: S235, S355



Features	<p>Modified steerable SAW automat for cylinders and conical parts with parallel-wire technology</p> <p>High degree of stability thanks to serial axis prolongation</p> <p>Modified power sources for sufficient process reliability at long distances from the welding area</p>
Target	<p>Major reduction in production time thanks to huge increase in deposition rate assisted by the use of double-wire technology</p> <p>High productivity achieved through fully mechanised welding process for interior seams</p> <p>Savings in operating materials thanks to universal use of steerable automat for cylindrical and conical components (e.g. as wind turbine towers)</p>
System components	<p>Modified steerable automat for double-wire technology</p> <p>1 DC power source – type GTH 1402</p> <p>Pneumatic flux recovery unit in a closed circuit design</p>
Performance range	<p>100A/19V to 1,200A/44V at 100% duty cycle</p> <p>Welding speeds of up to 60 cm/min</p> <p>Diameter of welding wire 2 x 2 to 2 x 3 mm</p> <p>Butt welds in PA position (flat)</p> <p>Fillet welds in PB position (horizontal vertical)</p> <p>Hoses and cables up to 50,000 mm in length</p>
Applied benefits	<p>Optimised engineering systems for welding complete towers, resulting in approx. 30% less labour time</p> <p>Automat base frame retains high degree of stability despite highly conical geometry of tube sections</p> <p>Maximum processing roadway dependent only on the media supply</p>

Surfacing automat

Fully mechanised GMAW welding gantry – type VT



Application

Surfacing of plates for the manufacturing of wear plates

GMAW welding with flux cored wire

Cladding

Max. workpiece dimensions 3,500 x 2,000 x 200 mm

Material: Independent of application



Features	<p>An existing portal has been equipped with special GMAW welding technology</p> <p>Local exhaust for occupational safety and environmental protection</p>
Target	<p>Significant increase in productivity in the range of 130% through automation of the surfacing process</p> <p>High process reliability through elimination of negative influence of incorrect torch management and distance</p> <p>Time saving and cost efficiency through use of full scope of system with several torches</p>
System components	<p>2 DC power sources – type GTH 802</p> <p>2 water-cooled flux cored torches with a power rating of 500 A</p> <p>Central operating console for peripheral equipment and welding technology</p>
Performance range	<p>100A/19V to 1,000A/44V at 100% duty cycle</p> <p>Welding speed depends on process</p> <p>Diameter of flux cored wire max. 3.2 mm</p> <p>Cladding in PA position (flat)</p>
Applied benefits	<p>High savings in production time as well as huge reductions in workload and improved quality</p> <p>Low workpiece warpage thanks to simultaneous surfacing with several welding torches</p>

Surfacing automat

Automatic GMAW welding gantry – type TAK

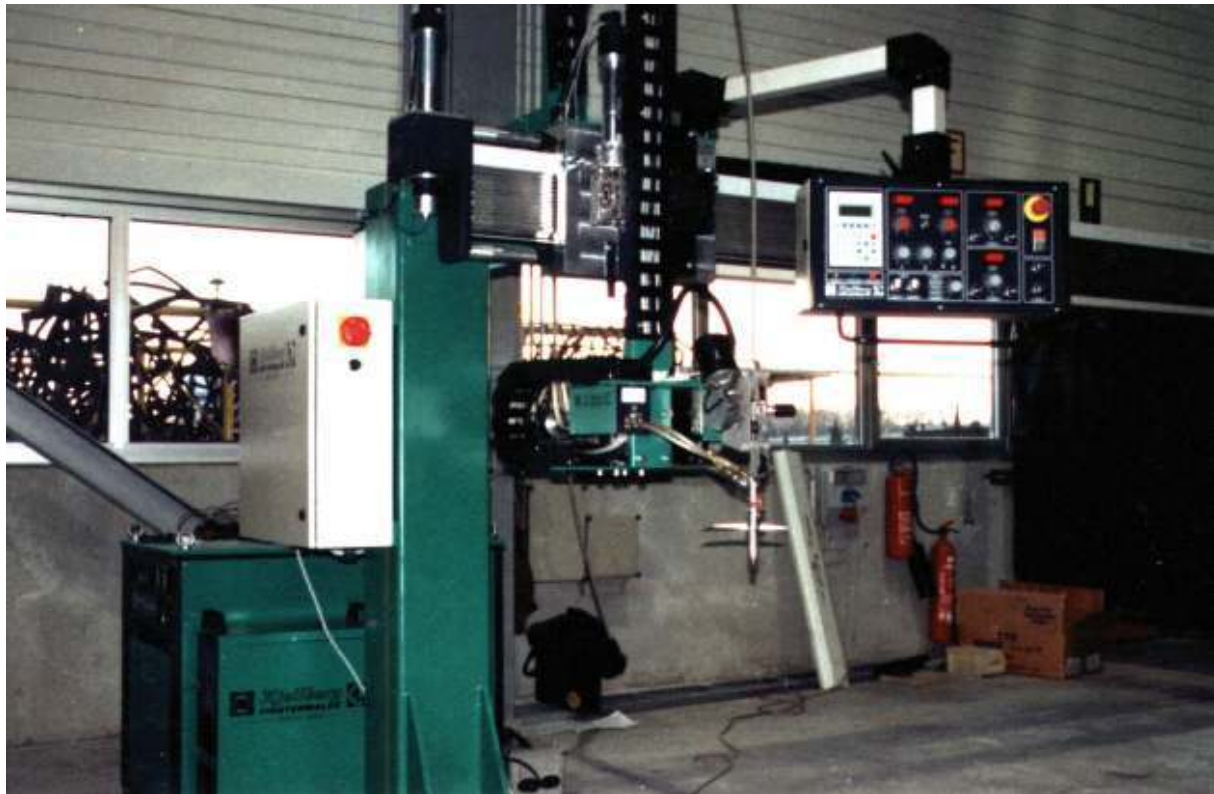

Application

Surfacing on mining components, conveyor parts and heavy industry workpieces

GMAW welding with flux cored wires

Cladding and regeneration

Max. component dimensions 3,000 x 600 x 500 mm

Material: Depends on alloy of flux cored wire



Features	Automation of surfacing for regeneration and wear protection purposes
Target	<p>Significant increase in productivity (approx. 70%) and reduction in workload thanks to complete equipment mechanisation in comparison to "manual flux cored wire welding"</p> <p>Low error rate due to automated surfacing with a recordable program sequence</p> <p>Substantial decrease in staff workload and reduction in set-up times through use of turntable for workpiece handling</p>
System components	<p>Power source type GTH 1002</p> <p>Water-cooled flux cored machine torch with four-rolled wire feeder</p> <p>Oscillation support for surfacing</p> <p>Central operating console for peripheral components and welding technology with stored program control (SPC)</p>
Performance range	<p>100A/19V to 1,000A/44V at 100% duty cycle</p> <p>Welding speeds of up to 50 cm/min</p> <p>Diameter of welding wire max. 3.2 mm</p> <p>Cladding in PA position (flat) and PB position (horizontal vertical)</p>
Applied benefits	<p>Increase in productivity by approx. 60% thanks to oscillation device and high degree of mechanisation</p> <p>Occupational safety and environmental protection through external process control and program flow</p> <p>High process reliability, reduced heat input and low crack origin due to fixed program sequences geared to the respective welding task</p>

Surfacing automat

Automatic SAW Surfacing Unit – type SMS



Application

Surfacing on running wheels and guide wheels

SAW single wire welding

Regeneration

Diameter of work-piece between 300 and 1000 mm

Weight of work-piece between 150 and 450 kg

Material: unalloyed and low-alloyed mild steel



Features	<p>Automated surfacing for regeneration purposes</p> <p>Surfacing of running surfaces and edges is made possible by integrating a pivoting work-piece support</p> <p>Very high flexibility and easy transport due to compact structure of the unit with optimum arrangement of the individual components within the overall system</p>
Target	<p>Regeneration of components which are prone to wear and tear in order to save regular investments</p> <p>Very high process liability due to automated process with monitoring of parameters</p> <p>Compact version for transport in sea freight containers</p>
System components	<p>1 welding power source of the type GTH 1002</p> <p>1 pressure powder conveyor with a capacity of 50l, heated and with minimum level indicator</p> <p>1 KA 2-UP welding head</p> <p>1 rotating-tilting table with a maximum load of 750kg on the face plate</p> <p>1 machine frame with main column and motor supporting cross</p>
Performance range	<p>Max. 1.000A/ 44V at 100% duty cycle, optimum working range starts at 450A</p> <p>Welding speed up to 90 cm/min depending on diameter of work-piece and weld pool movement</p> <p>Wire diameter 3.0 mm</p> <p>Surfacing in positions PA and PB</p>
Applied benefits	<p>Huge cost savings by regeneration of consumables</p> <p>High productivity and process reliability</p> <p>Flexible positioning of the unit because it can be transported with forklift</p>

Surfacing automat

Automatic SAW surfacing column and boom manipulator – type RAD



Application

Surfacing on wheelsets

SAW and GMAW welding

Regeneration

Workpiece diameter up to 1,300 mm

Infeed depth up to 450 mm

Material: Filling material depending on welding job

Surfacing automat

Mobile GMAW welding system – type KAB



Application

Surfacing on worn cylindrical components

GMAW welding with Innershield wires

Cladding and regeneration

Max. workpiece diameter approx. 3,000 mm

Workpiece height approx. 300 mm

Materials: Depends on availability of filling materials



Features	Mobile surfacing equipment for regeneration and wear protection purposes
Target	Significant increase in productivity by approx. 150% through automated surfacing High increase in quality compared to the manual method previously used Option of partial disassembly of system with a view to its deployment in customer's locality and to saving time on transportation of parts for welding
System components	1 power source – type GTH 802 1 water-cooled flux cored machine torch with four-roller drive Central operating console for welding technologies and peripheral components Water-cooling unit with flow control
Performance range	80A/18V to 720A/44V at 100% duty cycle Welding speeds of up to 80 cm/min Diameter of welding wire max. 2.8 mm Cladding in PA position (flat) and PB position (horizontal vertical)
Applied benefits	Significant increase in productivity and alleviation of workload compared to "manual welding" in the range of 200% Occupational safety thanks to external process and program control High degree of flexibility and mobility due to segmental construction

Surfacing system for railways

Fully mechanised machine for surfacing onto rails



Application

Regeneration of grooved rails

SAW welding

Layer structure of vertical groove flanks

Material: Railroad steel



Features	<p>Optional use of solid wire or flux cored wire</p> <p>Facility for adjustment to a maximum track width of 1,500 mm according to the type of rail</p> <p>Waterproofed wire feeder housing</p>
Target	<p>Significant reduction in working time thanks to regeneration of grooved rails in mobile on-site applications using fully mechanised welding technology</p> <p>High seam quality thanks to uniform layers in the area of straight tracks, curves and switches</p>
System components	<p>1 DC power source – type GTH 802 – modified for operating in generator mode</p> <p>SAW single wire welding head with flexible hollow cables for wire diameters of up to 2.5 mm</p> <p>Pneumatic flux recovery unit</p> <p>Hoses and cable 35,000 mm in length</p>
Performance range	<p>80A/18V to 720A/44V at 100% duty cycle</p> <p>Welding speeds of up to 70 cm/min</p> <p>Diameter of welding wire up to 2.5 mm</p> <p>Layer structure in PC position (horizontal)</p>
Applied benefits	<p>Decrease in operative time, secondary processing time and downtime</p> <p>Mechanised welding on left or right groove flank, no re-positioning of the welding system necessary</p> <p>Stable welding construction in six-wheel version</p> <p>Minimum flux loss and long distances achievable with pneumatic flux recovery unit</p> <p>Flexibility regarding work location thanks to rubber wheels for ease of positioning and their infeed by electrical lifting cylinders</p>

Kjellberg – KA series welding machines

Good value standard technology for a range of engineering applications

Based on a **flexible modular system**, the KA machine series **offers cost-effective solutions** for a range of technological applications with a view to streamlining operations and **realising potential savings**.

In the stiff competition between metalworking enterprises, you can secure benefits for yourself by deploying this standard technology, achieving:

- **Major reductions in labour time** through mechanisation and reaching high welding speeds and high welding output.
- **Reliable welding quality** in SAW process thanks to optimum welding performance, high pore reliability, excellent seam quality, and tachometer-controlled wire feeder and tractor drives
- **Strong decrease in secondary process times** thanks to mechanised operations, various flux recovery units, optimum slag retracking quality, fast support positioning
- **Cost reductions** due to high durability of wear parts (nozzle, feed rollers), low-wear and dustproof support newels, retrofit options for additional technology (sensors) and variable guide roll application, elimination of glare shield and welding fume exhaust
- **Savings on labour costs through the use of semi-skilled, rotating personnel** made possible by user-friendly, ergonomic controls and high degree of process reliability due to parameter pre selection for current, voltage and welding speed (preset) allows automatic process for start options and crater filling at the end of welding or choice of separate welding programs at a second operating level
- **High degree of occupational safety** due to avoidance of glare thanks to covered arc (by flux) at the workplace and in the whole workshop environment, very low weld fumes (no exhaustion), increased stability through axis prolongations, etc.

Basic version KA 1-UP

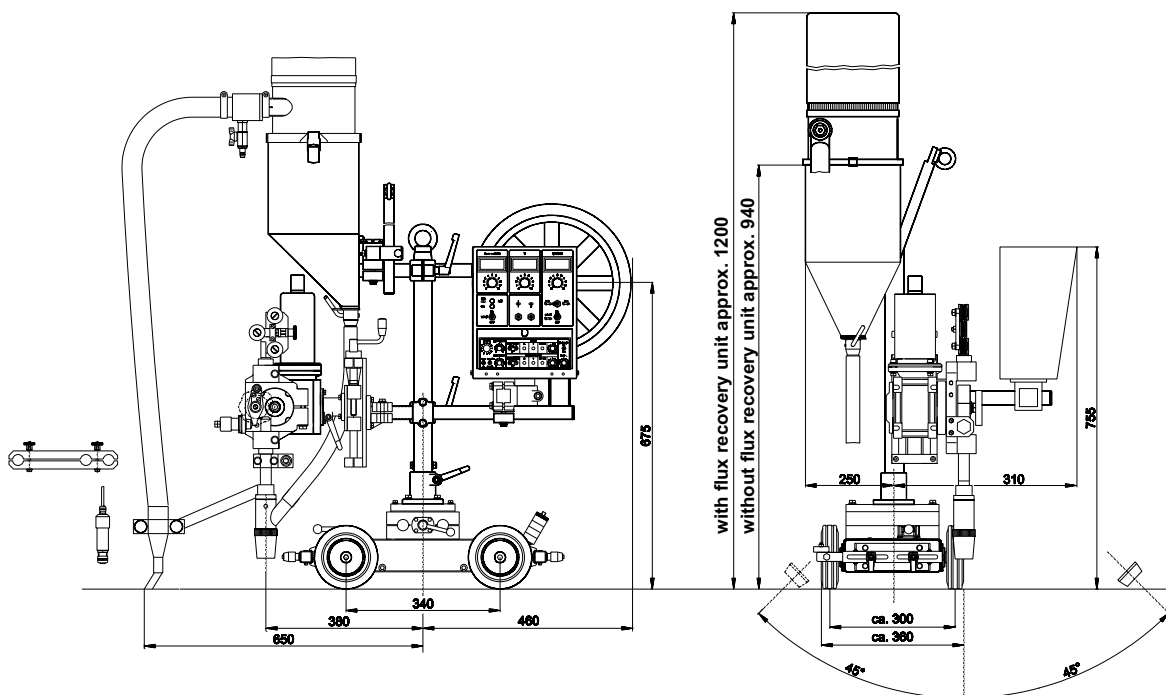

Standard designs



KA 1-UP



KA 1-UP
steered machine



KA 2-UP



KA 4-UPDG



KA 7-UPP

Type	Specification	Max. welding power	Wire diameter (mm)	Recommended welding power sources
KA 1-UP	SAW single wire tractor	800 A	1.6 – 3	GTH 522 GTH 802
		1,400 A	2.5 – 5	GTH 1002 GTH 1402
KA 1-UP steered machine	SAW single wire tractor, designed for tank and pipe inner welding (e.g. wind turbine towers)	1,400 A	2.5 – 5	GTH 1002 GTH 1402
KA 2-UP/UPP	Single wire welding head	800 A	1.6 – 3	GTH 802
		1,400 A	2.5 – 5	GTH 1002 GTH 1402
		1,400 A	2 x 1.6 to 2 x 3	GTH 1002 GTH 1402
KA 4-UPDG	SAW double-hinged arm tractors (welding of two fillet or butt welds simultaneously)	600 A (per welding head)	1.6 to 2.5 (per welding head)	2 x GTH 522 2 x GTH 802
KA 7-UPP	SAW parallel tractor also available as steered machine	1,400 A	2 x 1.6 to 2 x 3	GTH 1002 GTH 1402

Specifications of power sources for Kjellberg KA series machines

DC power source	GTH 522 ¹⁾	GTH 802	TTH 1000 (welding transformer)
Order number	.11.907.702	.11.705.902A	.11.690.902
Procedure	SAW, GMAW	SAW, GMAW	SAW
Characteristic	constant voltage (cv)	constant voltage (cv)	constant voltage (cv)
Supply voltage	3x 400 V, -10%/+10%, 50 Hz	3x 400 V, -10%/+10%, 50 Hz	2x 400 V, -10%/+10%, 50 Hz
Power input acc. to EN 60974-1	23,6 kVA	31,7 kVA	77,2 kVA
Power supply	CEE 63 A	CEE 63 A	terminal connection, fuse 200 A
Welding current	70 A / 18 V – 500 A / 45 V	80 A / 18 V – 800 A / 44 V	200 A / 25 V – 1,000 A / 44 V
X = 60 %	500 A	–	–
X = 80 %	–	800 A	–
X = 100 %	400 A	720 A	1,000 A
Protection	IP 23	IP 22	IP 23
Weight	260 kg	319 kg	650 kg
Dimensions L x W x H (mm)	1,130 x 665 x 865 (with building site chassis)	980 x 720 x 1,000 (with building site chassis)	1,350 x 770 x 870 (stationary)

DC power source	GTH 1002	GTH 1402
Order number	.11.903.102A	.11.903.802A
Procedure	SAW, GMAW	
Characteristic	constant voltage (cv)	
Supply voltage	3 x 400 V, - 10 % / + 10 %, 50 Hz	
Power input acc. to EN 60974-1	78 kVA	83,8 kVA
Power supply	terminal connection, fuse 125 A	terminal connection, fuse 125 A
Welding current	100 A / 19 V – 1,000 A / 44 V	100 A / 19 V – 1,400 A / 44 V
X = 100 %	1,000 A	1,200 A
Protection	IP 21	IP 21
Weight	440 kg	440 kg
Dimensions L x W x H (mm)	1,110 x 820 x 1,000 (stationary)	1,110 x 820 x 1,000 (stationary)

DC power source	GTF 752	GTF 1002	GTF 1402
Order number	.11.705.702	.11.903.202	.11.903.702
Procedure	SAW (gouging)	SAW (MMAW, gouging)	SAW (MMAW, gouging)
Characteristic	constant current (cc)	constant current (cc)	constant current (cc)
Supply voltage	3 x 400 V, -10 % / +10 %, 50 Hz		
Power input acc. to EN 60974-1	51,5 kVA	78 kVA	83,8 kVA
Power supply	CEE 125 A (option 63 A)	terminal connection, fuse 125 A	terminal connection, fuse 125 A
Welding current	60 A / 22,4 V – 750 A / 44 V	200 A / 28 V – 1,000 A / 44 V	200 A / 28 V – 1,400 A / 44 V
X = 80 %	750 A	–	1,400 A
X = 100 %	630 A	1,000 A	1,200 A
Protection	IP 22	IP 21	IP 21
Weight	304 kg	438 kg	438 kg
Dimensions L x W x H (mm)	980 x 720 x 1,000 (with building site chassis)	1,110 x 820 x 1,000 (stationary)	1,110 x 820 x 1,000 (stationary)

1) with integrated cooling water circulation, can also be supplied without on request

09-12-04

Kjellberg®
FINSTERWALDE

Kjellberg Finsterwalde Schweißtechnik und
Verschleißschutzsysteme GmbH

Germany 58453 Witten Stockumer Str. 28
Phone: +49 2302 661-648 Fax: +49 2302 661-658

Germany 03238 Finsterwalde Leipziger Str. 66-68
Phone: +49 3531 500-319 Fax: +49 3531 500-357

Email: schweissen@kjellberg.de Web: www.kjellberg.de

Our products are characterised by high quality and reliability. We reserve the right to make changes to volume production for technical reasons. No claims of any kind can therefore be made on the basis of the information contained in this brochure.



Kjellberg® and **FINSTERWALDE** are trademarks of the Kjellberg Foundation or an associated company which are registered in Germany and/or other countries.

Copyright © 2009
Kjellberg Finsterwalde Schweißtechnik und
Verschleißschutzsysteme GmbH
All rights reserved.